

# ACTIVE BATTERY MANAGEMENT SYSTEM REC ACTIVE BMS



 **REC**  
*Control your power!*

Novi trg 9, 6230 Postojna, Slovenia  
mail: [info@rec-bms.com](mailto:info@rec-bms.com); [www.rec-bms.com](http://www.rec-bms.com)

## Features:

- robust and small design
- 4 cells connections
- up to 8 temperature sensors
- single cell voltage measurement (0.1 – 5.0 V, resolution 1 mV)
- single cell - under/over voltage protection
- single cell internal resistance measurement
- SOC and SOH calculation
- over temperature protection
- under temperature charging protection
- active cell balancing up to 2.5 A DC per cell
- shunt current measurement (resolution 19.5 mA @  $\pm 500$  A)
- galvanically isolated user defined multi-purpose digital output
- programmable relay (normally open or normally closed)
- galvanically isolated RS-485 communication protocol
- CAN communication (customizable)
- error LED + buzzer indicator
- 11 ERROR log on the device FIFO
- PC user interface for changing the settings and data-logging (optional accessory)
- hibernate switch
- one IP65 protected connector for all connections
- ISO16315, ISO10133, EN61558-1, EN61558-2 and EN50498 compliant

## INDEX:

General Description of the BMS Unit: .....	3
Hardware Parameters:.....	4
ABMS Power Supply:.....	4
Default Software Parameters: .....	5
System Overview: .....	6
BMS Unit Connections: .....	7
Setting the RS-485 Address:.....	8
BMS Unit Connector: .....	8
BMS Unit Connector, Cells Part: .....	8
BMS Unit Power Supply: .....	9
BMS Unit Connection Instructions:.....	9
RS-485 Communication Protocol:.....	9
CAN Communication (Hardware and Software on demand): .....	14
BMS Unit Start Procedure:.....	17
BMS Unit LED Indication: .....	17
Cell Voltage Measurement: .....	17
BMS Cell Balancing:.....	17
Balancing START Voltage: .....	17
Balancing END Voltage:.....	17
Cell Internal DC Resistance Measurement: .....	18
Battery Pack Temperature Measurement: .....	18
BMS Current Measurement:.....	18
Voltage-to-current Coefficient:.....	19
Battery Pack SOC Determination: .....	19
Battery Pack's Charging Algorithm: .....	20
Battery Pack's Discharging Algorithm:.....	20
ABMS Outputs Settings:.....	21
Digital Outputs: .....	22
Pre-charge Connection: .....	23
Parallel Cells Connection: .....	24
System Error Indication: .....	25
BMS Unit Dimensions: .....	28

## **General Description of the BMS Unit:**

The Battery management system (BMS) monitors and controls each cell in the battery pack by measuring its parameters. The capacity of the battery pack differs from one cell to another and this increases with number of charging/discharging cycles. The Li-poly batteries are fully charged at typical cell voltage 4.16 - 4.20 V or 3.5 – 3.7 V for LiFePO<sub>4</sub>. Due to the different capacity this voltage is not reached at the same time for all cells in the pack. The lower the cell's capacity the sooner this voltage is reached. When charging series connected cells with a single charger, voltage on some cells might be higher than the maximum allowed voltage. Overcharging the cell additionally lowers its capacity and number of charging cycles. The BMS equalizes cells' voltage by diverting some of the charging current from higher voltage cells to the whole pack or from the whole pack to a lower voltage cells – active balancing. The device's temperature is measured to protect the circuit from over-heating due to unexpected failure. Battery pack's temperature is monitored by Dallas DS18B20 digital temperature sensor/s. Current is measured by a low-side shunt resistor. Battery pack current, temperature and cell's voltage determine state of charge (SOC). State of health (SOH) is determined by comparing cell's current parameters with the parameters of a new battery pack. The BMS default HW parameters are listed in Table 1.

## Hardware Parameters:

**Table 1: ABMS hardware parameters.**

Parameter	Value	Unit
BMS maximum pack voltage	16.8	V
BMS minimum pack voltage	10	V
BMS minimum pack voltage (HW UVP)	10.85	V
BMS maximum cell voltage	5.0	V
Shunt common mode input voltage interval (Shunt+, Shunt -) to the Cell 1 negative	-0.3 to 3.0	V
Shunt sensor max differential input voltage interval (Shunt+ to Shunt -)	-0.25 to 0.25	V
Cell voltage accuracy	+/-3	mV
Pack voltage accuracy	+/-6	mV
DC current accuracy	+/- 1	LSB
Temperature measuring accuracy	+/-0.5	°C
DC Current sample rate	3	Hz
Cell voltage sample rate	0.8	Hz
Cell balancing current	2.5	A
Maximum operating temperature*	70	°C
Minimum operating temperature*	-20	°C
Maximum storage temperature*	30	°C
Minimum storage temperature*	0	°C
Maximum humidity*	75	%
max DC current relay @ 60 V DC	0.7	A
max AC current relay @ 230 V AC	2	A
max DC current @ optocoupler	15	mA
max DC voltage@ optocoupler	62.5	V
BMS unit disable power supply	< 1	mW
BMS unit stand-by power supply	< 60	mW
BMS unit cell balance fuse rating	3.15 slow	A
internal relay fuse	3.15 slow	A
dimensions (w × l × h)	105 x 135 x 44	mm
IP protection	IP65	
HW version	2.1	n.a.

\*defined by internal RTC back-up 2032 battery

## ABMS Power Supply:

**Table 2: BMS power supply.**

Battery voltage[V]	Supply current [mA]*
11	25.6
12	23.3
13	21.4
14	19.8
15	18.3
16	17.1

\*Normal mode (only main relay and charge optocoupler are active)

## Default Software Parameters:

**Table 3:** Default BMS parameter settings\*.

Parameter	Value	Unit
chemistry	3 (LiFePO <sub>4</sub> )	n.a.
capacity	200	Ah
balance start voltage	3.45	V
balance end voltage	3.58	V
maximum diverted current per cell	up to 2.5 (5 pp)	A
cell over-voltage switch-off per cell	3.85	V
over-voltage switch-off hysteresis per cell	0.25	V
cell end of charge voltage	3.58	V
End of charge hysteresis per cell	0.25	V
SOC end of charge hysteresis	5	%
cell-under voltage protection switch-off per cell	2.8	V
under voltage protection switch-off hysteresis per cell	0.1	V
cell under voltage discharge protection (CAN communication only)	2.9	V
cells max difference	0.25	V
BMS over-temperature switch-off	55	°C
BMS over-temperature switch-off hysteresis	5	°C
cell over temperature switch-off	55	°C
cell over temperature switch-off hysteresis	2	°C
under temperature charging disable	-10	°C
under temperature charging disable hysteresis	2	°C
voltage to current coefficient	0.01171875	A/bit
current measurement zero offset	0.0	A
maximum charging/discharging current per inverter/charger device (CAN communication only)	120/250	A
number of inverter/charger devices (CAN communication only)	1	n.a.
charge coefficient (CAN communication only)	0.6	n.a.
discharge coefficient (CAN communication only)	1.5	n.a.
charge optocoupler 1 voltage level	3.58	V
charge optocoupler 1 voltage level hysteresis	-0.2	V
optocoupler 2 voltage level	2.9	V
optocoupler 2 voltage level hysteresis	0.2	V
CAN communication frequency	250	kbit/s
SW version	5.0	n.a.

\*all parameters values may be changed with PC user interface.

**System Overview:**

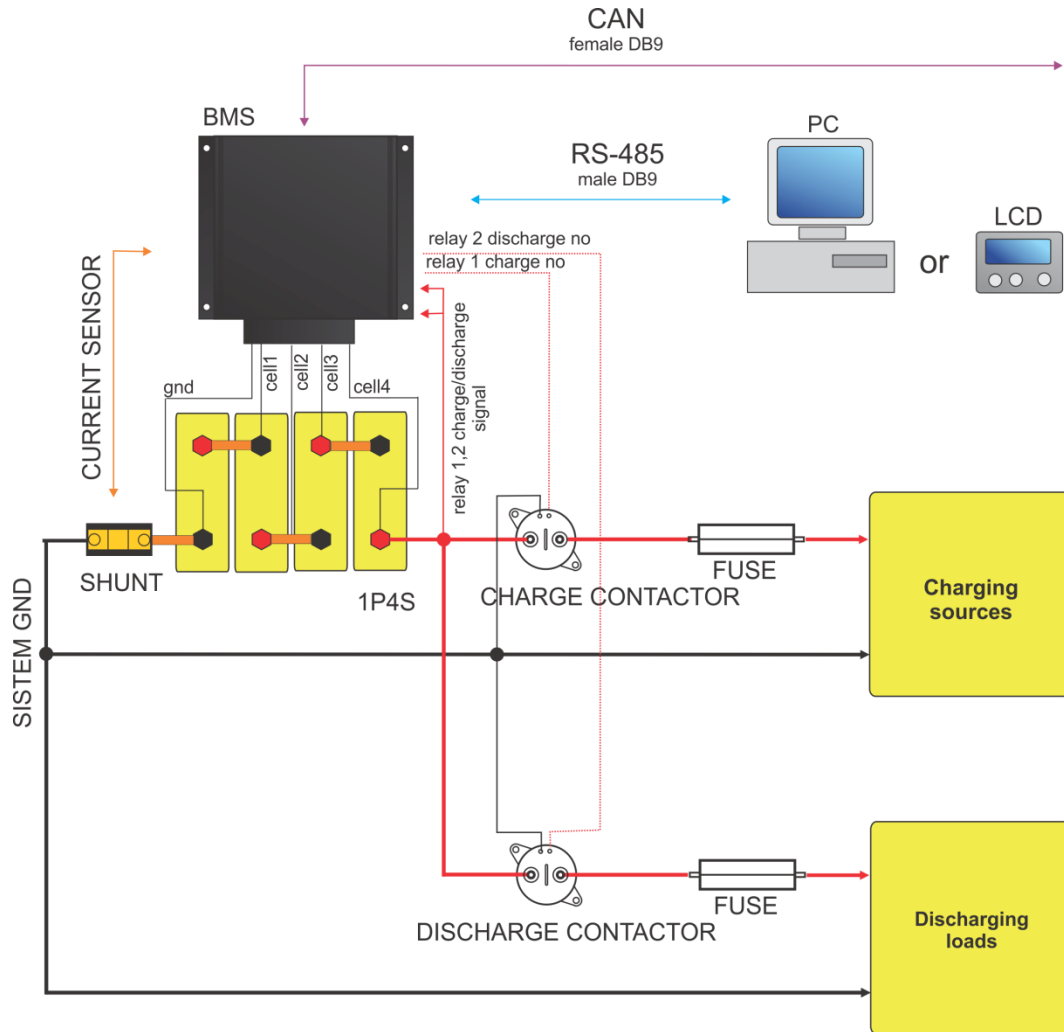

**Figure 1:** System overview.

## BMS Unit Connections:

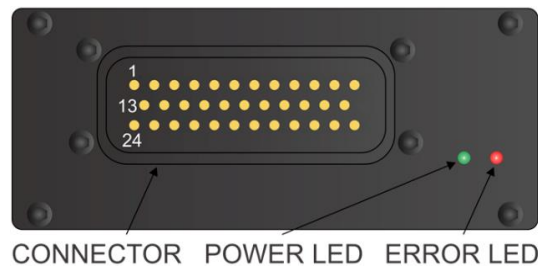

**Figure 2:** BMS unit front panel function overview.

**Table 4:** BMS unit male socket connections.

Connection	Designator	Description	Cable Wiring Label
1	Charge relay 1	Normally closed	
2	Charge relay 1	Fused input	RELAY CH F
3	Discharge relay 2	Normally closed	
4	Discharge relay 2	Normally open	RELAY DCH NO
5	Discharge relay 2	Fused input	RELAY DCH F
6	Hibernate switch signal	-	
7	Hibernate switch ground	-	
8	Cell 4 <b>positive +</b>	Analog signal	CELL 4+
9	Cell 3 <b>positive +</b>	Analog signal	CELL 3+
10	Cell 2 <b>positive +</b>	Analog signal	CELL 2+
11	Cell 1 <b>positive +</b>	Analog signal	CELL 1+
12	Cell 1 <b>negative -</b>	Analog signal	CELL 1-
13	Charge relay 1	Normally open	RELAY CH NO
14	Charge optocoupler 1 – user defined collector	-	OPTO CH C
15	Charge optocoupler 1 – user defined emitter (darlington + reverse protection diode + polyfuse)	-	OPTO CH E
16	Optocoupler 2 – user defined collector	-	OPTO DCH C
17	Optocoupler 2 – user defined emitter (darlington + reverse protection diode + polyfuse)	-	OPTO DCH E
18	CAN Vcc	4.6 V output, max 10 mA	CAN
19	CANL	-	CAN
20	RS485 Vcc	-	RS485
21	RS485 A	-	RS485
22	RS485 ground	-	RS485
23	RS485 B	-	RS485
24	Shunt-	-	
25	Shunt+	-	
26	Shunt shield	-	
27	Dallas 18B20 temp. sensor	GND + shield	
28	Dallas 18B20 temp. sensor	+ 5 V	
29	Dallas 18B20 temp. sensor	1-wire digital signal	
30	CANH	-	CAN



31	CAN ground	GND potential of the battery pack	CAN
32	-	-	
33	Address pin 3	Normally 0, connect to pin 35 to change to 1	
34	Address pin 2	Normally 0, connect to pin 35 to change to 1	
35	Address pin ground	Fused ground for Address pins	

### Setting the RS-485 Address:

Address of the BMS unit is selected via the Address pins. Factory address is 2. Formula for changing the address is:

$$\text{ActiveBMS ADDRESS} = 2^2 * \overline{\text{Address pin 3}} + 2^1 * \overline{\text{Address pin 2}} + 2^0$$

**! If multiple BMS units are used distinguished addresses should be set to avoid data collision on the RS-485 communication bus!**

### BMS Unit Connector:

Before starting the assembly please go to website:

<http://www.te.com/catalog/pn/en/776164-1?RQP=776164-1>

...and read the connector assembly datasheet:

*AMPSEAL Automotive Plug Connector and Header Assembly in Application Specification and AMPSEAL Automotive Plug Assemblies 776268... in Instruction Sheet (U. S.).*

### BMS Unit Connector, Cells Part:

Connect each cell to the BMS unit cell connector plug. Use silicon wires with cross section of 0.5 – 1.4 mm<sup>2</sup> (20-16 AWG). **! Before inserting the connector check the voltage and polarity of each connection!**

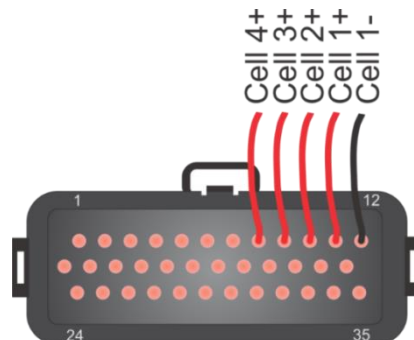

**Figure 3:** Battery pack connection plug – front side.

## BMS Unit Power Supply:

BMS unit is always supplied from the 4-th cell connection.

## BMS Unit Connection Instructions:

Connect all necessary connections to the BMS connector first, check the polarities and then plug the female connector into the BMS. When the system components are plugged in, the enable switch can be turned ON and the unit starts the test procedure. Connection instruction video link: <http://www.rec-bms.com/ABMS.html>

When disconnecting the unit from the battery pack, the procedure should be followed in reverse order.

## RS-485 Communication Protocol:



**Figure 4:** RS-485 DB9 connector front view.

**Table 5:** RS-485 DB9 connector pin designator.

pin	designator
1	-
2	AGND
3	B
4	A
5	-
6	+5V to AGND
7	-
8	-
9	-

Galvanically isolated RS-485 (EN 61558-1, EN 61558-2) serves for logging and changing BMS parameters. Dedicated PC BMS Control Software or another RS-485 device may be used for the communication. Default RS-485 address is 2.

Unlock password: Serial without the first minus e.g. 1A-XXXX.

Messages are comprised as follows:

STX, DA, SA, N, INSTRUCTION- 4 bytes, 16-bit CRC, ETX

- STX start transmission <0x55> (always)
- DA - destination address <0x01> to <0x10> (set as 6)
- SA - sender address <0x00> (always 0)
- N – number of sent bytes

- INSTRUCTION 4 bytes for example.: 'L','C','D','1','?', - (combined from 4 ASCII characters, followed by '?', if we would like to receive the current parameter value or '','xx.xx' value in case we want to set a new value
- 16-bit CRC - big endian, for the whole message except STX in ETX - <https://www.lammertbies.nl/comm/info/crc-calculation.html>
- ETX - end transmission <0xAA> (always)

Dataflow:

- Bit rate: 56k
- Data bits: 8
- Stop bits: 1
- Parity: None
- Mode: Asynchronous
- Little endian format when an array is sent

**Table 6:** RS-485 instruction set.

INSTRUCTION	DESCRIPTION	BMS ANSWER	SETTING INTERVAL
*IDN?	Identification	Answer "REC - BATTERY MANAGEMENT SYSTEM"	Read only
<b>ARRAYS INSTRUCTIONS</b>			
LCD1?	Main data	First answer is 28 – how many byte data will be sent and then data message follows as 7 float values: LCD1 [0] = min cell voltage, LCD1 [1] = max cell voltage, LCD1 [2] = current, LCD1 [3] = max temperature, LCD1 [4] = pack voltage, LCD1 [5] = SOC (state of charge) interval 0-1-> 1=100% and LCD1 [6] = SOH (state of health) interval 0-1-> 1=100%	Read only
LCD3?	Main data	First answer is 8 – how many byte data will be sent and then data message follows as 8 byte values: LCD3 [0] = min cell BMS address, LCD3 [1] = min cell number, LCD3 [2] = max cell BMS address, LCD3 [3] = max cell number, LCD3 [4] = max temp. sens. BMS address, LCD3 [5] = max temp. sens. number, LCD3 [6] = Ah MSB, LCD3 [7] = Ah LSB	Read only
CELL?	Cell voltages	BMS first responds with how many BMS units are connected, then it sends the values of the cells in float format	Read only

PTEM?	Cell temperatures	BMS first responds with how many BMS units are connected then it sends the values of the temperature sensors in float format	Read only
RINT?	Cells internal DC resistance	BMS first responds with how many BMS units are connected then it sends the values in float format	Read only
BTEM?	BMS temperature	BMS first responds with value 1, then it sends the values of the BMS temperature sensor in float format	Read only
ERRO?	Error number description array	First answer is 4 – how many byte data will be sent and then data message follows as 4 byte values: ERRO [0] = 0 – no error, 1 – error ERRO [1] = BMS unit ERRO [2] = error number (1-16) and ERRO [3] = number of the cell, temp. sensor where the error occurred	Read only
<b>CELL SETTINGS INSTRUCTIONS</b>			
BVOL? or BVOL x.xx	Balance end voltage	Returns float voltage [V]	2.5 to 4.30 V
BMIN? or BMIN x.xxx	Balancing start voltage	Returns float voltage [V]	2.5 to 4.30 V
CMAX? or CMAX x.xx	Cell over-voltage switch-off	Returns float voltage [V]	2.0 to 4.30 V
MAXH? or MAXH x.xx	Over- voltage switch-off hysteresis per cell	Returns float voltage [V]	0.005 to 2.0 V
CMIN? or CMIN x.xxx	Cell-under voltage protection switch-off	Returns float voltage [V]	1.8 to 4.00 V
MINH? or MIN x.xxx	Over- voltage switch-off hysteresis per cell	Returns float voltage [V]	0.005 to 2.0 V
CHAR? Or CHAR x.xxx	Cell End of charging voltage	Returns float voltage [V]	2.0 to 4.30 V
CHIS? Or CHIS x.xxx	End of charging voltage hysteresis per cell	Returns float voltage [V]	0.005 to 2.0 V
RAZL? or RAZL x.xx	Cells max difference	Returns float voltage [V]	0.005 to 1.0 V
<b>TEMPERATURE SETTINGS INSTRUCTIONS</b>			
TMAX? or TMAX x.xxx	cell over temperature switch-off	Returns float temperature [°C]	-20 to 65 °C
TMIN? or TMIN x.xxx	Under-temperature charging disable	Returns float temperature [°C]	-30 to 65 °C
TBAL? or TBAL x.xxx	BMS over-temperature switch-off	Returns float temperature [°C]	-20 to 65 °C
BMTH? or BMTH x.xxx	BMS over temperature switch-off hysteresis	Returns float temperature [°C]	1 to 30 °C

<b>CURRENT SETTINGS INSTRUCTIONS</b>			
IOFF? or IOFF x.xxx	Current measurement zero offset	Returns float current [A]	-2.0 to 2.0 A
IOJA? Or IOJA x.xxx	Voltage to current coefficient	Returns float value	0.0005 to 0.5
<b>BATTERY PACK SETTINGS INSTRUCTIONS</b>			
CYCL? or CYCL xx	Number of full battery pack cycles	Returns integer value	0 to 8000
CAPA? or CAPA x.xxx	Battery pack capacity	Returns float capacity [Ah]	1.0 to 3000.0 Ah
CHEM? or CHEM xx	Li-ion chemistry	Returns unsigned char value	1 to 5
<b>SOC SETTINGS INSTRUCTIONS</b>			
SOCH? or SOCH x.xxx	SOC end of charge hysteresis	Returns float value 0 – 1.0	0.005 to 0.99
SOCS? or SOCS x.xx	SOC manual re-set	Returns float value 0 – 1.0	0.01 to 1.00
<b>CHARGING/DISCHARGING CAN COMMUNICATION SETTINGS INSTRUCTIONS</b>			
CHAC? or CHAC x.xxx	Charge coefficient (0-5C)	Returns float value 0-5.0 (default 0.6)	0.01 to 5.0
DCHC? or DCHCx.xxx	Discharge coefficient (0-5C)	Returns float value 0-5.0 (default 1.5)	0.01 to 5.0
STRN? or STRN xx	Number of inverter devices on the bus	Returns unsigned char value (default 1)	1 to 6
MAXC? or MAXC x.xxx	Maximum charge current per inverter device	Returns float current [A]	5.0 to 280.0 A
MAXD? or MAXD x.xxx	Maximum discharge current per inverter device	Returns float current [A]	5.0 to 400.0 A
CLOW? or CLOW x.xxx	cell under-voltage discharge protection	Returns float voltage [V]	1.8 to 4.20 V
CANF? or CANF xx	CAN Frequency	Returns unsigned integer value 100, 125, 200, 250, 500 or 1000	100, 125, 200, 250, 500 or 1000 kbit/s
WHCL 1	Wh counter reset	Resets charge and discharge Wh counter	n.a.
<b>ERROR LOG INSTRUCTIONS</b>			
ERRL?	Returns error log data (FIFO register of the last 12 errors). By sending the same instruction the data pointer shifts from the last error entry to the first error entry, then it starts all over again	Returns "xx,zz; hh:mm:ss;dd.mm.yyyy" xx-error number zz-number of the cell/temp sensor	Read only
ERLD? or ERLD 1	Error log delete	Returns unsigned char value. To reset Error log set ERLD to 1 and restart the ABMS.	0, 1
VMAX? or VMAX xx	Number of exceeded values of CMAX	Returns integer value	0 to 8000
VMIN? or VMIN xx	Number of exceeded values of CMIN	Returns integer value	0 to 8000
<b>OUTPUTS SETTINGS INSTRUCTIONS</b>			

OP1L? or OP1L x.xxx	Optocoupler 1 voltage level	Returns float voltage [V]	1.8 to 4.30 V
OP1H? or OP1H x.xxx	Optocoupler 1 voltage level hysteresis	Returns float voltage [V]	-2.0 to 2.0 V 0.0 V enables charge control
OP2L? or OP2L x.xxx	Optocoupler 2 voltage level	Returns float voltage [V]	1.8 to 4.30 V
OP2H? or OP2H x.xxx	Optocoupler 2 voltage level hysteresis	Returns float voltage [V]	-2.0 to 2.0 V 0.0 V disables output
<b>ABMS SETTINGS INSTRUCTIONS</b>			
CAL1? or CAL1 x.xxx	Cell 1 calibration offset	Returns float voltage [V]	-0.030 to 0.030 V
CAL2? or CAL2 x.xxx	Cell 2 calibration offset	Returns float voltage [V]	-0.030 to 0.030 V
CAL3? or CAL3 x.xxx	Cell 3 calibration offset	Returns float voltage [V]	-0.030 to 0.030 V
CAL4? or CAL4 x.xxx	Cell 4 calibration offset	Returns float voltage [V]	-0.030 to 0.030 V
SERI? or SERI xx	ABMS Serial number	Returns unsigned integer 0 - 9999	1-9999
SWVR?	ABMS software version	Returns string	Read only
HWVR?	ABMS hardware version	Returns string	Read only
TIME? or TIME xx:xx:xx	ABMS RTC Time	Returns/accepts "hh:mm:ss" format*	-
DATE? or DATE xx.xx.xxxx	ABMS RTC DATE	Returns/accepts "dd.mm.yyy" format*	-
WCIB?	Which cell is being balanced	Returns cell number	Read only

\*BMS->Time/Date pop-up window can be used to set both values at once.

Parameter accepted and changed value is responded with 'SET' answer.

Example: proper byte message for 'LCD1?' instruction for BMS address 2 is:

```
<0x55><0x02><0x00><0x05><0x4C><0x43><0x44><0x31><0x3F><0x53><0x90><0xAA>
```

RS-485 message is executed when the microprocessor is not in interrupt routine so a timeout of 350 ms should be set for the answer to arrive. If the timeout occurs the message should be sent again. Little endian format is used for all sent float or integer values. In case of single data is sent ASCII characters are used e.g. -1.2351e2

Custom made instructions can be added to the list to log or set the parameters that control the BMS algorithm or its outputs.

Video instruction link for settings change: [https://www.youtube.com/watch?v=sRr\\_5vBKupw](https://www.youtube.com/watch?v=sRr_5vBKupw)

Video instruction link for firmware update: <https://www.youtube.com/watch?v=2di-Dpv2Nf8>

## CAN Communication (Hardware and Software on demand):

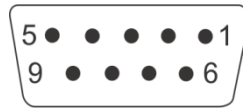

Figure 5: CAN female DB9 connector front view.

Table 7: CAN DB9 connector pin designator.

pin	designator
1	
2	CANL + TERMINATION*
3	GND
4	
5	-
6	
7	CANH + TERMINATION*
8	-
9	+ 4.6V

\* Termination plug with 120 R

No termination is used inside ABMS connector. **Terminate pins 2 and 7 with 120 Ohm resistor to prevent ABMS to reset.** Additional RJ45 connector with 120 Ohms across CANL and CANH should be used for the end device on the CAN bus for end termination. When the CAN frequency is changed via RS-485 instruction, BMS has to be reset to enable the new setting.

### Pre-programmed CAN communication

11-bit TX identifiers: 0x031, 0x032, 0x033, 0x034, 0x035, 0x036, 0x037.

Table 8: CAN message 0x031 structure description (charging/discharging restrictions).

Byte	Description	Type	Property
1	Max charge voltage low byte	Unsigned integer	LSB = 0.1 V
2	Max charge voltage high byte		
3	Max charging current low byte	Signed integer	LSB = 0.1 A
4	Max charging current high byte		
5	Max charging current low byte	Signed integer	LSB = 0.1 A
6	Max charging current high byte		
7	Max discharge voltage low byte	Unsigned integer	LSB = 0.1 V
8	Max discharge voltage high byte		

Table 9: CAN message 0x032 structure description.

Byte	Description	Type	Property
1	Battery voltage low byte	unsigned integer	LSB = 1 mV
2	Battery voltage high byte		
3	Battery current low byte	Signed integer	LSB = 0.02 A
4	Battery current high byte		
5	SOC	Unsigned char	LSB = 1 %
6	SOH	Unsigned char	LSB = 1 %
7	Outputs status	Unsigned char	Bit 1: Charge relay 1 Bit 2: Discharge relay 2 Bit 3: Charge optocoupler 1 Bit 4: Optocoupler 2

**Table 10:** CAN message 0x033 structure description (charging/discharging restrictions).

Byte	Description	Type	Property
1	Cell 1 voltage low byte	Unsigned integer	LSB = 1 mV
2	Cell 1 voltage high byte		
3	Cell 2 voltage low byte	Unsigned integer	LSB = 1 mV
4	Cell 2 voltage high byte		
5	Cell 3 voltage low byte	Unsigned integer	LSB = 1 mV
6	Cell 3 voltage high byte		
7	Cell 4 voltage low byte	Unsigned integer	LSB = 1 mV
8	Cell 4 voltage high byte		

**Table 11:** CAN message 0x034 structure description.

Byte	Description	Type	Property
1	MAX temperature	Signed char	LSB = 1° C
2	MIN temperature	Signed char	LSB = 1° C
3	Capacity low byte	Unsigned integer	LSB = 1 Ah
4	Capacity high byte		
5	Remaining capacity high byte	Unsigned integer	LSB = 1 Ah
6	Remaining capacity low byte		
7	Error number	Unsigned char	0 - 16
8	Error number element	Unsigned char	0 - 4

**Table 12:** CAN message 0x035 saved Wh structure description.

Byte	Description	Type	Property
1	Charged Wh first byte	Unsigned long	LSB = 100 Wh
2	Charged Wh second byte		
3	Charged Wh third byte		
4	Charged Wh forth byte		
5	Discharged Wh first byte	Unsigned long	LSB = 100 Wh
6	Discharged Wh second byte		
7	Discharged Wh third byte		
8	Discharged Wh forth byte		

**Table 13:** CAN message 0x036 HW and SW structure description.

Byte	Description	Type	Property
1	BMS HW number main version	ASCII	2.1
2	ASCII '.'		
3	BMS HW number sub version		
4	BMS SW number main version	ASCII	5.0
5	ASCII '.'		
6	BMS SW number sub version		



**Table 14:** CAN message 0x037 BMS serial number structure description.

Byte	Description	Type	Property
1	ASCII '1'	ASCII	1
2	ASCII 'A'		A
3	ASCII '-'		-
4	BMS serial MSB (1000)		e.g. 1305
5	BMS serial (100)		
6	BMS serial (10)		
7	BMS serial LSB (1)		
8	Not used - 0	Unsigned char	0

CAN messages are sent every 200 ms.

### **BMS Unit Start Procedure:**

When the BMS unit is turned ON it jumps into a boot-loader and checks if the user tries to upload a new firmware. Then it commences the test procedure by checking the balancing fuses and temperature sensors. After the test procedure red error LED turns off and the BMS unit starts working in normal mode.

### **BMS Unit LED Indication:**

Power LED (green) is turned on for 0.2 s every 2 s signaling that the BMS powered. When the battery pack is fully charged and SOC/end of charge hysteresis are set POWER LED is turn 100% on. Error LED (red) is turned on in case of system error and signals the error number with 50 % duty cycle. Between repeated error number 1 s timeout is introduced.

### **Cell Voltage Measurement:**

Cell voltages are measured every second. The cell measurement performs 4 ms cell measurement by Sigma Delta ADC. Each cell voltage is measured after the balancing fuse, in case the fuse blows, BMS signals error 10 to notify the user.

### **BMS Cell Balancing:**

Cells are balanced actively with very high efficiency in opposite to passive balancing, where all energy is lost in heat. Another benefit of active balancing is charging of dangerously low cell, if other cells are above dangerous level, consequently longer pack usage is possible.

### **Balancing START Voltage:**

If errors 2, 4, 5, 8, 10, 12 are not present and the highest cell voltage rises above Balance START voltage and current is  $> 0.2$  A (charging stage) the BMS initiates balancing algorithm. A weighted cell voltage average is determined including cells DC internal resistance. Balancing algorithm calculates the voltage above which the cells are balanced. The lowest cell voltage is taken into account determining balancing voltage.

### **Balancing END Voltage:**

If errors 2, 4, 5, 8, 10, 12 are not present any cell is above balance END voltage are balanced regardless the battery pack current.

### Cell Internal DC Resistance Measurement:

Cell internal DC resistance is measured as a ratio of a voltage change and current change in two sequential measurement cycles. If the absolute current change is above 20 A, cells internal resistance is calculated. Moving average is used to filter out voltage spikes errors.

### Battery Pack Temperature Measurement:

Battery pack temperatures are measured by Dallas DS18B20 digital temperature sensor/s. Up to two sensors can be used in parallel connected directly to the wiring. Up to 8 sensors may be used with a junction box. BMS should be turned off and main connector disconnected before adding sensors. If the temperature sensors wiring is placed near the power lines shielded cables should be used.

### BMS Current Measurement:

Low-side only precision shunt resistor for current measurement is used. A 4-wire Kelvin connection is used to measure voltage drop on the resistor. As short as possible **shielded cable** should be used to connect the power shunt and BMS. The battery pack current is measured every second. A high precision Sigma-Delta ADC is used to filter out the current spikes. The first current measurement is timed at the beginning of the cell measurement procedure for a proper internal DC resistance calculation. Two more 300 ms measurements are performed through the whole ABMS measurement interval Shunt connection is shown in Fig. 6. If the BMS measures charging/discharging current that is higher than the double value of the rated shunt for more than 2 consecutive cycles error 12 is triggered. This serves for shunt, contactor and fuse protection in case of short circuit.

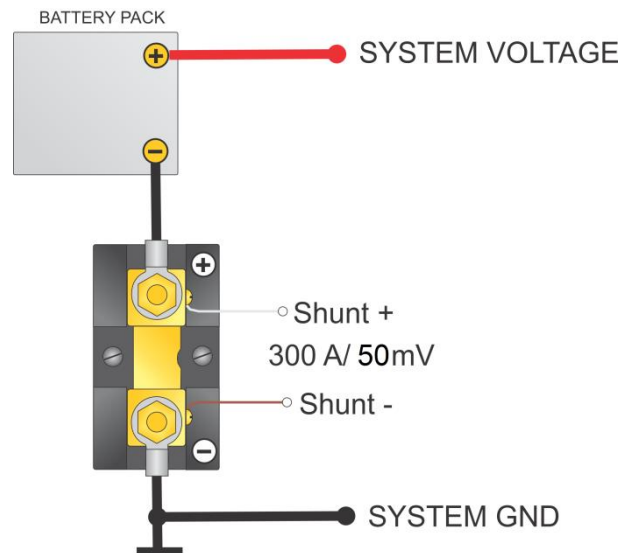

Figure 6: 300 A/50 mV shunt resistor connection.

### Voltage-to-current Coefficient:

Different size and resistance shunts can be used, since the voltage-to-current coefficient can be changed in the BMS Control software as IOJA x.xxxx. Current is calculated by the voltage drop at the shunt resistor. 1 LSB of the 18-bit ADC represents different current values according to the shunt resistance. The LSB coefficient can be calculated as:

$$k_{LSB} = 0.01171875 \cdot \frac{0.05 \text{ V}}{300 \text{ A}} \cdot \frac{I_{\text{currentx}}}{V_{\text{dropx}}}$$

where the  $V_{\text{dropx}}$  represents the voltage drop on shunt resistor at current  $I_{\text{currentx}}$ .

### Battery Pack SOC Determination:

SOC is determined by integrating the charge in or out of the battery pack. Different Li-ion chemistries may be selected:

**Table 15:** Li-ion chemistry designators.

Number	Type
1	Li-Po Kokam High power
2	Li-Po Kokam High capacity
3	Winston/Thunder-Sky/GWL LiFePO4
4	A123
5	Li-ion NMC/ LiMn <sub>2</sub> O <sub>4</sub>

Temperature and power correction coefficient are taken into consideration at the SOC calculation. Li-Po chemistry algorithms have an additional voltage to SOC regulation loop inside the algorithm. Actual cell capacity is recalculated by the number of the charging cycles as pointed out in the manufacturer's datasheet.

When BMS is connected to the battery pack for the first time, SOC is set to 50 %. SOC is reset to 100 % at the end of charging. Charging cycle is added if the coulomb counter had reached the battery pack's capacity.

### **Battery Pack's Charging Algorithm:**

If the highest cell reaches the cell over-voltage switch-off per cell CMAX threshold Charge relay 1 is turned off. Relay turns back on after the highest cell is balanced down under the cell over-voltage switch-off per cell - cell over-voltage switch-off hysteresis.

When the last cell rises to the End of Charge Voltage, End of Charge SOC hysteresis and End of charge cell voltage hysteresis is set. SOC is calibrated to 100 % and Power LED lights ON 100 %.

SOC is also calibrated to 96 % when the maximum open circuit cell voltage rises above the  $0.502 \times$  (Balance start voltage + balance end voltage), minimum open circuit voltage above balance start voltage and system is in charge regime (current > 2 A).

If the Charge optocoupler 1 hysteresis is set to 0, this digital optocoupler output functions like charger enable. Charge optocoupler 1 is turned ON until the last cell reaches END of charge voltage. If a single or multiple cell reach the voltage level between cell over-voltage switch-off and end of charge, output is turned OFF, until this/these cells are balanced down to end of charge voltage. Some of the errors also turn the output off. See Error table 16.

Charging is stopped in case of systems errors (See System Errors indication chapter). SOC is calibrated to 96 % when the maximum open circuit cell voltage rises above the  $0.502 \times$  (Balance start voltage + balance end voltage), minimum open circuit voltage above balance start voltage and system is in charge regime.

### **Battery Pack's Discharging Algorithm:**

When the lowest cell voltage is discharged below the set threshold CLOW maximum allowed discharging current starts to decrease down to 0.05 C (5 % of Capacity in A). After decreasing down, maximum allowed discharging current is set to 0 A. SOC is reset to 3 % and Discharging SOC hysteresis is set to 5 %. If the cell discharges below cell-under voltage protection switch-off per cell CMIN, ABMS signals Error 2 and SOC is reset to 1 %. Discharge relay 2 is turned off with cell-under voltage protection switch-off hysteresis to prevent relay ringing.

## ABMS Outputs Settings:

System devices can be controlled by digital outputs Charge optocoupler 1 and Discharge optocoupler 2.

### Charge optocoupler 1

Charge optocoupler 1 may be programmed to function in three ways. As a charger enable signal (Charge optocoupler 1 hysteresis OP1H is set to 0, OP1L is irrelevant in this case). If OP1H hysteresis is set to a positive value, digital output functions as an under-voltage protection – OP1L should be set to a threshold voltage level under which the output turns off.

If OP1H hysteresis is set to a negative value, digital output functions as an over-voltage protection – OP1L should be set to a threshold voltage level over which the output turns off.

### Discharge optocoupler 2

Discharge optocoupler 2 may be programmed to function in two ways only. If OP2H hysteresis is set to a positive value, digital output functions as an under-voltage protection – OP2L should be set to a threshold voltage level under which the output turns off.

If OP2H hysteresis is set to a negative value, digital output functions as an over-voltage protection – OP2L should be set to a threshold voltage level over which the output turns off.

If OP2H hysteresis is set to 0, output is disabled.

#### EXAMPLE 1:

We want to use Charge optocoupler 1 as over - charge control. Charge optocoupler 1 should switch off if the highest cell reaches 3.7 V with 0.15 V hysteresis. In communicate window we set:

```
OP1L 3.7  
OP1H -0.15
```

#### EXAMPLE 2:

We want to use Discharge optocoupler 2 as discharge control. Optocoupler 2 should switch off if the lowest cell drops under 2.70 V with 0.25 V hysteresis. In communicate window we set:

```
OP2L 2.70  
OP2H 0.25
```

#### EXAMPLE 3:

We want to use Charge optocoupler 1 as charger enable control. In communicate window we set:

```
OP1H 0
```

## Digital Outputs:

Digital outputs are implemented with galvanic isolation. Optocouplers with diode reverse protection are used. When closed, a 0.7 V voltage drop over the digital output should be taken into account. Optocoupler outputs can drive a small signal relay or LED diodes. Fig. 7 shows two different connection schematics. Both outputs can be used to drive LED diodes for charge/discharge relay indication.

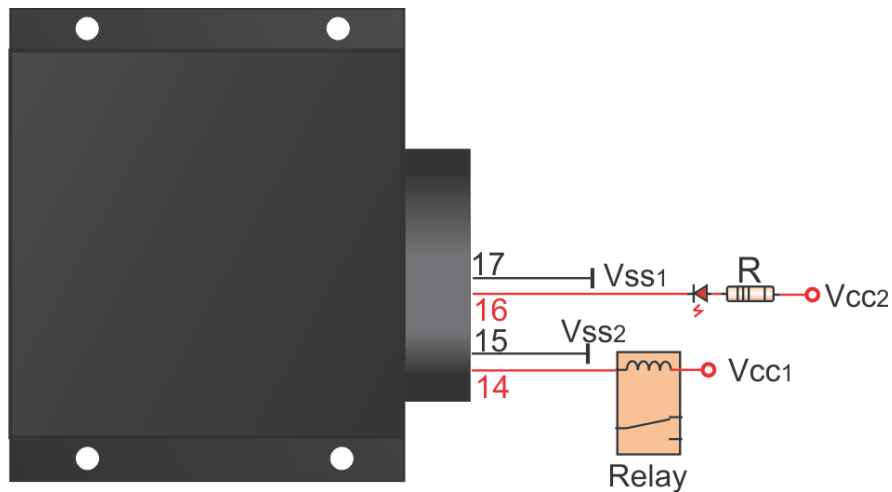

**Figure 7:** BMS digital outputs schematics.

Current limit resistor R can be calculated as:

$$R = \frac{V_{CC2} - 0.7 V - V_{FVLED}}{I_{LED}}$$

$V_{FVLED}$  represents LED forward voltage drop (typ. 1.9 – 2.3 V) while  $I_{LED}$  represents LED current (2-5 mA).

### Pre-charge Connection:

Charging/discharging contactors are driven by charge/discharge relays 1 and 2 inside the BMS. If a high input/output capacity ( $> 2,000 \mu\text{F}$ ) is used at the charging sources/discharging loads, a pre-charge unit should be used to avoid high in-rush current spikes when the contactor is turned on. In-rush currents degrade the contactor, cells and input capacitors in the electronic device. Fig. 8 shows contactor connection with the pre-charge circuit in discharge DC-rail. In case the charging source also use high output capacity a pre-charge unit should be used also in the charge DC-rail.

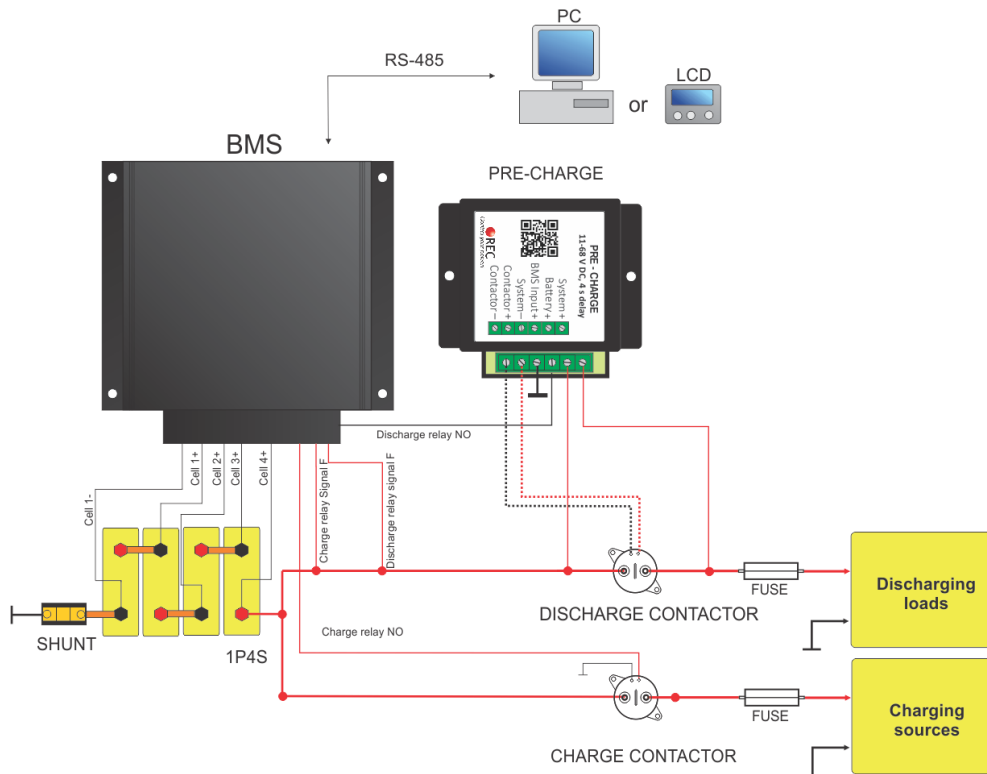
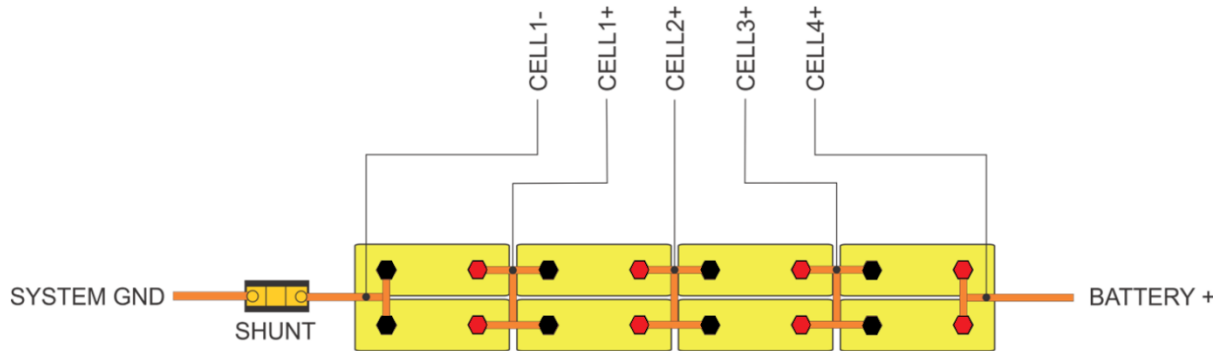

**Figure 8:** Contactor connection schematics.



### Parallel Cells Connection:

Capacity can be increased by connecting multiple cells in parallel and then connect these sub-packs in series. Fig. 9 shows 2P4S connection with 2 cells in parallel and 4 pack like this in series. **For proper current distribution 2 connection bars should be used between each 2P to 2P sub-pack.**



**Figure 9:** 2P4S battery pack connection.

## System Error Indication:

System errors are indicated with **red** error LED by the number of ON blinks, followed by a longer OFF state. Each and every error number trigger algorithm has a normal delay time of 3 measuring cycles with sensed/measured error – 3 x 1.25 s before the error is triggered.

Errors 2 and 10 are set to trigger @ the first measured error when the BMS is turned ON. If the two errors are not present normal delay timer is set.

**Table 16:** BMS error states.

Number of ON blinks	ERROR	BMS	OWNER
1	Single or multiple cell voltage is too high (cell over voltage switch-off per cell + cell over-voltage switch-off hysteresis per cell ).	BMS will try to balance down the problematic cell/cells to safe voltage level (2.5 s error hysteresis + single cell voltage hysteresis is applied). Charge relay is disconnected. Discharge relay 2 is connected. In case charge optocoupler is set to charger enable it is disconnected.	<ul style="list-style-type: none"> <li>• Wait until the BMS does its job.</li> </ul>
2	Single or multiple cell voltage is too low (cell under voltage protection switch-off per cell + under voltage protection switch-off hysteresis per cell).	BMS will try to charge the battery (2.5 s error hysteresis + single cell voltage hysteresis is applied). SOC is reset to 1 % Charging relay 1 is enabled, discharging relay 2 is disabled. In case charge optocoupler is set to charger enable it is connected.	<ul style="list-style-type: none"> <li>• Plug in the charging sources.</li> </ul>
3	Cell voltages differs more than set (cells max difference)	BMS will try to balance the cells if balancing is enabled (20 mV voltage difference hysteresis). Charging relay 1 is enabled, discharging relay 2 is enabled.	<ul style="list-style-type: none"> <li>• Wait until the BMS does its job. If the BMS is not able to balance the difference in a few hours, contact the service.</li> </ul>
4	Cell temperature is too high (cell over temperature switch-off + cell over temperature switch-off hysteresis).	Cells temperature or cell inter-connecting cable temperature in the battery pack is/are too high. (2.5 s error hysteresis 2°C hysteresis). All outputs are disabled.	<ul style="list-style-type: none"> <li>• Wait until the pack cools down.</li> </ul>

5	BMS temperature is too high –internal error (BMS over temperature switch-off + BMS over-temperature switch-off hysteresis).	Due to extensive cell balancing/hardware error the BMS temperature rose over the upper limit (2.5 s error hysteresis + 5 °C temperature hysteresis). All outputs are disabled.	<ul style="list-style-type: none"> <li>• Wait until the BMS cools down.</li> </ul>
6	Number of cells, address is not set properly.	All outputs are disabled.	<ul style="list-style-type: none"> <li>• Set proper ABMS address</li> </ul>
7	The temperature is too low for charging (under temperature charging disable + under temperature charging disable hysteresis).	If cells are charged at temperatures lower than operating temperature range, cells are aging much faster than they normally would, so charging is disabled (2 °C temperature hysteresis). Charge relay is disconnected. Discharge relay 2 is connected. In case charge optocoupler is set to charger enable it is disconnected.	<ul style="list-style-type: none"> <li>• Wait until the battery's temperature rises to usable range.</li> </ul>
8	Temperature sensor error.	Temperature sensor is un-plugged or not working properly (2.5 s error hysteresis). All outputs are disabled.	<ul style="list-style-type: none"> <li>• Turn-off BMS unit and try to re-plug the temp. sensor. If the BMS still signals error 8, contact the service. The temperature sensors should be replaced.</li> </ul>
9	Communication error.	RS-485 Master-Slave communication only.	
10	Cell in short circuit or BMS measurement error (Max cell voltage > 4.5 V or Min cell voltage < 0.8 V).	Single or multiple cell voltage is close to zero or out of range, indicating a blown fuse, short circuit or measuring failure (15 s error hysteresis + 10 mV voltage difference hysteresis). All outputs are disabled.	<ul style="list-style-type: none"> <li>• Turn-off the BMS and check the cells connection to the BMS and fuses. Restart the BMS.</li> <li>• If the same error starts to signal again contact the service.</li> </ul>
11	Discharge relay 2 is in short circuit.	If the discharge relay 2 should be opened, all the other outputs are set to control charging and current < -0.5 A, the BMS signals error 11. All outputs are disabled.	<ul style="list-style-type: none"> <li>• Restart the BMS unit. If the same error starts to signal again examine the discharge relay 2 output on the BMS, pre-charge unit and contactor.</li> </ul>

12	Current measurement disabled or charging/discharging current >2 x shunt max current	ABMS is not able to measure current or current is too high for charging or discharging. All outputs are disabled.	<ul style="list-style-type: none"> <li>Check the system settings/HW configuration. If the BMS still signals error 12, contact the service or change the BMS settings.</li> </ul>
13	Wrong cell chemistry selected.	In some application the chemistry pre-set is compulsory. All outputs are disabled.	<ul style="list-style-type: none"> <li>Use PC Control Software to set proper cell chemistry.</li> </ul>
14	EEPROM data corruption	During start-up or shut-down EEPROM read/write was interrupted. The corrupted setting/settings was/were set to a default value. If the setting/settings was/were changed after the first installation it/they should be corrected. All outputs are enabled.	<ul style="list-style-type: none"> <li>Use PC Control Software to set proper settings</li> </ul>
15	ABMS CAN bus communication baud rate error	Set CAN baud rate is not correct. All outputs are enabled. CAN is disabled.	<ul style="list-style-type: none"> <li>Use PC Control Software to set proper settings. 100k, 125k, 200k, 250k, 500k or 1M may be set.</li> </ul>
16	ABMS internal communication failure	I2C or SPI communication failure. BMS signals error 16 and does not start normal procedure. All outputs are disabled.	<ul style="list-style-type: none"> <li>Restart the BMS unit. If the same error starts to signal again contact the service.</li> </ul>

**BMS Unit Dimensions:**

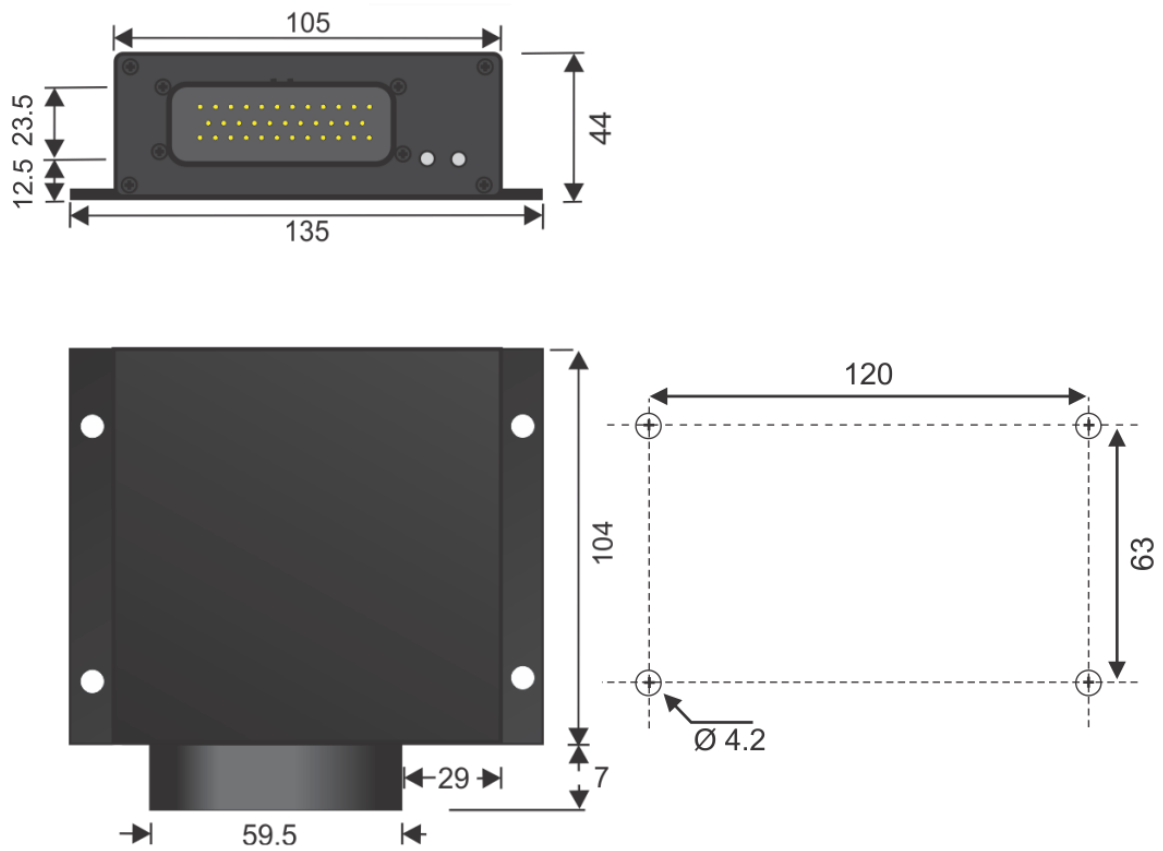

**Figure 10:** BMS dimensions.

M4 bolts are preferred to use for mounting. BMS unit can be also supplied without the enclosure, if an application is weight or space limited. The dimensions of the BMS (including connector) without the enclosure are 109 mm x 100 mm x 38 mm. The PCB has four 3.2 mm mounting holes.